

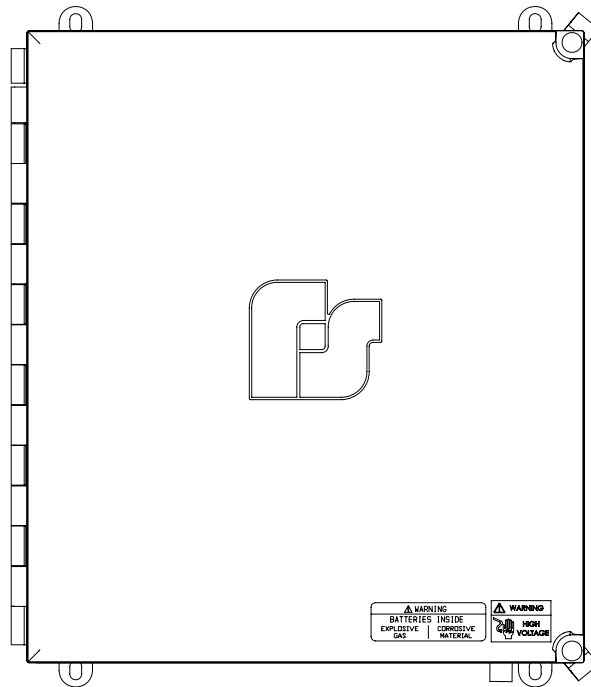

FEDERAL SIGNAL

Advancing security and well-being.



Federal Signal UltraVoicetm UVRI Controller

INSTALLATION and OPERATION INSTRUCTIONS

255385 Rev. A1
3/2010

Copyright 2009, 2010 Federal Signal Corporation

1 SAFETY NOTICES

People's lives depend on your selection of suitable equipment, installation sites and your safe installation, service, and operation of our products. Reference the following publications for warning system planning guidance: Federal Emergency Management Agency 1. "Outdoor Warning Guide (CPG 1-17), 2. "Civil Preparedness, Principles of Warning" (CPG 1-14), 3. FEMA-REP-1, Appendix 3 (Nuclear Plant Guideline), 4. FEMA-REP-10 (Nuclear Plant Guideline) and NFPA 72. Contact Alert and Notification System's Customer Care Center at: <http://www.alertnotification.com> or 1-800-524-3021 for further information about these publications.

It is important to read, understand and follow all instructions shipped with this product. In addition, listed below are some other important safety instructions and precautions you should follow.

PLANNING

- If suitable warning equipment is not selected, the installation site for the siren is not selected properly or the siren is not installed properly, it may not produce the intended optimum audible warning. Follow Federal Emergency Management Agency (FEMA) recommendations.
- If sirens or speakers are not activated in a timely manner when an emergency condition exists, they cannot provide the intended audible warning. It is imperative that knowledgeable people, who are provided with the necessary information, are available at all times to authorize the activation of the sirens or speakers.
- When sirens are used out of doors, people indoors may not be able to hear the warning signals. Separate warning devices or procedures may be needed to effectively warn people indoors.
- The sound output of sirens is capable of causing permanent hearing damage. To prevent excessive exposure, carefully plan siren placement, post warnings, and restrict access to areas near sirens.
- Activating the sirens or speakers may not result in people taking the desired actions if those to be warned are not properly trained about the meaning of warning sounds. Siren users should follow FEMA recommendations and instruct those to be warned of correct actions to be taken.
- A siren or speaker that doesn't work won't provide any warning. After installation, service, or maintenance, test the mass notification system to confirm that it is operating properly. Test the system regularly to confirm that it will be operational in an emergency.
- An Emergency Plan and Risk Analysis should be developed per applicable standards.
- If future service and operating personnel do not have these instructions, the notification system may not provide the intended audible warning and service personnel may be exposed to death, permanent hearing loss, or other bodily injury. File these instructions in a safe place and refer to them periodically. Give a copy of these instructions to new personnel and trainees. Also give a copy to anyone who is going to service or repair the notification system.

People's lives depend on your safe installation, service and operation of our products. It is important to read, understand and follow all instructions shipped with this product. In addition, listed below are some other important safety instructions and precautions you should follow:

INSTALLATION & SERVICE

- Electrocution or severe personal injury can occur when performing various installation and service functions such as making electrical connections, drilling holes, or lifting equipment. Therefore experienced electricians in accordance with national, state and any other electrical codes having jurisdiction should perform installation. All work should be performed under the direction of the installation or service crew safety foreman.
- The sound output of sirens or speakers is capable of causing permanent hearing damage. To prevent excessive exposure, carefully plan siren placement, post warnings and restrict access to areas near the sirens. Sirens and distributed speakers may be operated from remote control points. Whenever possible, disconnect all siren power including batteries before working near the siren.
- After installation or service, test the siren system to confirm that it is operating properly. Test the system regularly to confirm that it will be operational in an emergency.
- If future service personnel do not have these warnings and all other instructions shipped with the equipment, notification system may not provide the intended audible warning and service personnel may be exposed to death, permanent hearing loss, or other bodily injury. File these instructions in a safe place and refer to them periodically. Give a copy of these instructions to new personnel and trainees. Also, give a copy to anyone who is going to service or repair the notification system. For additional copies, call the Alert and Notification Systems Customer Care Center at 800-524-3021 or write to them at 2645 Federal Signal Drive, University Park, IL 60466.

OPERATION

- Failure to understand the capabilities and limitations of your notification system could result in permanent hearing loss, other serious injuries or death to persons too close to the sirens when you activate them or to those you need to warn. Carefully read and thoroughly understand all safety notices in this manual and all operations-related-items in all instruction manuals shipped with the notification system equipment. Thoroughly discuss all contingency plans with those responsible for warning people in your community, company, or jurisdiction.

WARNING

Read and understand the information contained in this manual, before attempting to install or service this product.

Pay careful attention to the following notices located on the equipment.

A. NOTICES - EXTERNALLY PLACED

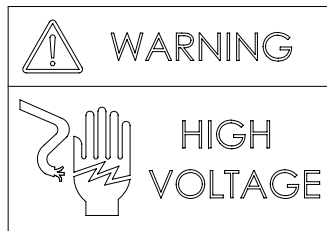

B. NOTICES-INTERNALLY PLACED

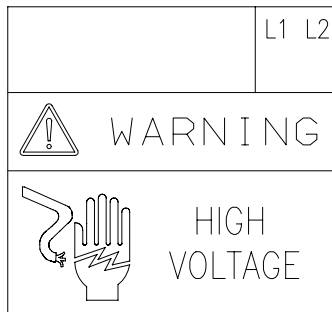

2 LIMITED WARRANTY

*The Public Safety Systems Division of **Federal Signal Corporation** warrants each new product to be free from defects in material and workmanship, under normal use and service, for a period of two years on parts replacement and factory-performed labor (one year for Informer, EAS, and Federal software products) from the date of delivery to the first user-purchaser. Federal Warning Systems warrants every 2001 & Eclipse Siren (Top of pole only) to be free from defects in material, per our standard warranty, under normal use and service for a period of five years on parts replacement.*

During this warranty period, the obligation of Federal is limited to repairing or replacing, as Federal may elect, any part or parts of such product which after examination by Federal discloses to be defective in material and/or workmanship.

Federal will provide warranty for any unit which is delivered, transported prepaid, to the Federal factory or designated authorized warranty service center for examination and such examination reveals a defect in material and/or workmanship.

This warranty does not cover travel expenses, the cost of specialized equipment for gaining access to the product, or labor charges for removal and re-installation of the product. The Federal Signal Corporation warranty shall not apply to components or accessories that have a separate warranty by the original manufacturer, such as, but not limited to, batteries.

Federal will provide on-site warranty service during the first 60-days after the completion of the installation, when Federal has provided a turn-key installation including optimization and/or commissioning services.

This warranty does not extend to any unit which has been subjected to abuse, misuse, improper installation or which has been inadequately maintained, nor to units which have problems related to service or modification at any facility other than Federal factory or authorized warranty service centers. Moreover, Federal shall have no liability with respect to defects arising in Products through any cause other than ordinary use (such as, for example, accident, fire, lightning, water damage, or other remaining acts of god).

THERE ARE NO OTHER WARRANTIES, EXPRESSED OR IMPLIED, INCLUDING BUT NOT LIMITED TO, ANY IMPLIED WARRANTIES OF MERCHANTABILITY OR FITNESS FOR A PARTICULAR PURPOSE. IN NO EVENT SHALL FEDERAL BE LIABLE FOR ANY LOSS OF PROFITS OR ANY INDIRECT OR CONSEQUENTIAL DAMAGES ARISING OUT OF ANY SUCH DEFECT IN MATERIAL WORKMANSHIP.



2645 Federal Signal Drive, University Park, IL 60484
Phone: (800) 548-7229, Fax: (708) 534-4865
Website: <http://www.alertnotification.com>

3 TABLE OF CONTENTS

Section	Page
1 SAFETY NOTICES	3
2 Limited Warranty	Error! Bookmark not defined.
3 TABLE OF CONTENTS	7
4 General Description.....	Error! Bookmark not defined.
4.1 Model Number Descriptions	11
4.2 UVRI Part Locations:.....	12
4.3 Initial Configuration.....	14
4.4 Programming Methods.....	19
4.5 Status Monitoring:	19
5 SPECIFICATIONS	20
5.1 Electrical.....	20
5.2 Power Supply	20
5.3 Battery.....	21
5.4 Relay Output	21
5.5 Control Board (2005141-05).....	21
5.6 Controller Front Panel Controls, Jacks, Switches and Indicators	22
5.7 Motherboard (2005320).....	26
5.8 Environmental	28
5.9 Physical.....	28
6 UVRI OPERATION.....	29
6.1 Hardware General Description	29
6.2 Manual Activation	29
6.3 Local Public Address.....	30
6.4 Relay Output	30
6.5 Sensor Inputs	30
6.6 Two-Way Status Monitoring	31
6.7 Quiet Test.....	32
6.8 DC Power Supply	32
7 SYSTEM PLANNING	33
7.1 Control Unit	33
8 INSTALLATION.....	34
8.1 UVRI Controller Installation Reference Drawings.....	34
8.2 General Mounting Guidelines.....	37
8.3 UVRI Installation Material List and Installation Guidelines	37
8.4 Installer Supplied UVRI Electrical Installation Material List	41
8.5 Electrical Connections.....	42
8.6 Remote System Sense Input.....	44
8.7 Landline Control Connection	45
8.8 Ethernet Connection.....	45

8.9	Antenna Types	45
8.10	Remote Mounted Magnetic Base Antenna Installation.....	45
8.11	Yagi Antenna Installation.....	46
8.12	Omni Antenna Installation	48
8.13	Turning Power On	52
9	PRE-OPERATION CHECKOUT AND TEST	53
9.1	Visual Inspection	53
9.2	Pre-Operation Checkout.....	53
9.3	Radio Transceiver Adjustment Procedure.....	54
9.4	Control and Status Monitoring.....	55
10	MAINTENANCE	56
10.1	General Maintenance	58
10.2	Troubleshooting	60
11	OPTIONS.....	61
11.1	Radio Control	61
11.2	Digital Voice Recording	61
11.3	Installation of User Supplied Radio Receivers	61
11.4	Model UVRI-IP	62
12	Final Assembly Drawing and Parts List.....	67

TABLE OF FIGURES

Figure 4.1 – UVRI Inside View.....	12
Figure 4.2 - UVRI Parts Layout.....	13
Figure 5.1 - Motherboard Outline Drawing	27
Figure 8.1 - Typical UVRI Installation Drawing	34
Figure 8.2 - UVRI Cabinet Dimensional Outline Drawing	35
Figure 8.3 – UVRI Wiring Diagram	36
Figure 8.4 – UVRI Remote System Sense, Audio Output and DC Power Connections	44
Figure 8.5 – Relay Output	44
Figure 8.6 - Yagi Antenna Installation Example.....	49
Figure 8.7 - Omni Antenna Installation Example	50
Figure 8.8 – Antenna Grounding Example	51
Figure 9.1 - Field Test Data Sheet.....	56
Figure 10.1 – UVRI Motherboard Connections.....	59
Figure 10.2 - UVRI Battery Location and Cover Plate Mounting Screws.....	59
Figure 12.1 – UVRI Final Assembly and Parts List.....	67

4 GENERAL DESCRIPTION

The UltraVoice Remote Interface (UVRI) provides remote control and status monitoring of Fire Alarm and PA systems to create a fully integrated indoor and outdoor Mass Notification System when used with the Federal Commander Digital Control System. The UVRI has a built-in radio transceiver interface, an RS232 port, and optional ethernet, satellite, and telephone line interfaces for tying into communication networks. Built-in warning tone generation, live voice and up to 8 minutes of local digital voice storage is included in all models.

The UVRI is housed in a non-metallic indoor/outdoor NEMA4X / UL50 rated enclosure suitable for wall mounting.

Features:

- 12VDC Operation
- Seven standard warning signals
- Single tone, Two-tone, DTMF, EAS and MSK decoders for remote siren control
- Integrated MSK radio modem with 128-bit encryption over radio or wire
- Local pushbutton control for 7 control functions
- Local microphone input
- Up to 8 minutes of digital voice storage
- Integrated radio modem
- RS232 port
- 2-Tone and DTMF decoders
- Radio Transceiver option
- Ethernet interface option
- 2-Way Satellite option
- Scrolling Message Display option
- Dedicated telephone line option
- Programmable radio receiver for Low Band, VHF, or UHF (optional)
- Windows^R based siren programming software (optional)
- Diagnostic LEDs
- Quiet Test Diagnostics – Checks tone generator with 20KHz tone
- Remotely adjustable line level audio output
- DPDT 10 amp relay output
- Battery backup with built-in power supply/battery charger and low voltage cutoff
- Activation Test – Monitors tone generator and remote contact closure input
- Stackable siren functions enable user pre-defined warning scenarios
- Programmable over wireless radio channel using SFCDWARE
- NEMA4X / UL50 rated enclosure with padlock hasp

Federal Signal UltraVoice
UVRI Installation and Operation Manual

4.1 Model Number Descriptions

All UVRI models are set up for 2-way control and status monitoring using the Federal Commander Digital Control system. All models include 8 minutes of digital voice storage. Custom digital voice recording requires a model DVR.

<u>CONTROLLER OPTIONS</u>	<u>UVRI MODEL #</u>
NO RADIO (RF)	UVRI
UHF BAND Transceiver	UVRIU
HIGH BAND Transceiver	UVRIH
Landline Control	UVRI-LL
Ethernet Control	UVRI-IP
Satellite Control	UVRI-SAT

Option Exclusions:

The UVRI-IP and UVRI-SAT options cannot be used with any other options listed above at the same time.

Federal Signal UltraVoice
UVRI Installation and Operation Manual

4.2 UVRI Part Locations:



Figure 4.1 – UVRI Inside View

Federal Signal UltraVoice
UVRI Installation and Operation Manual

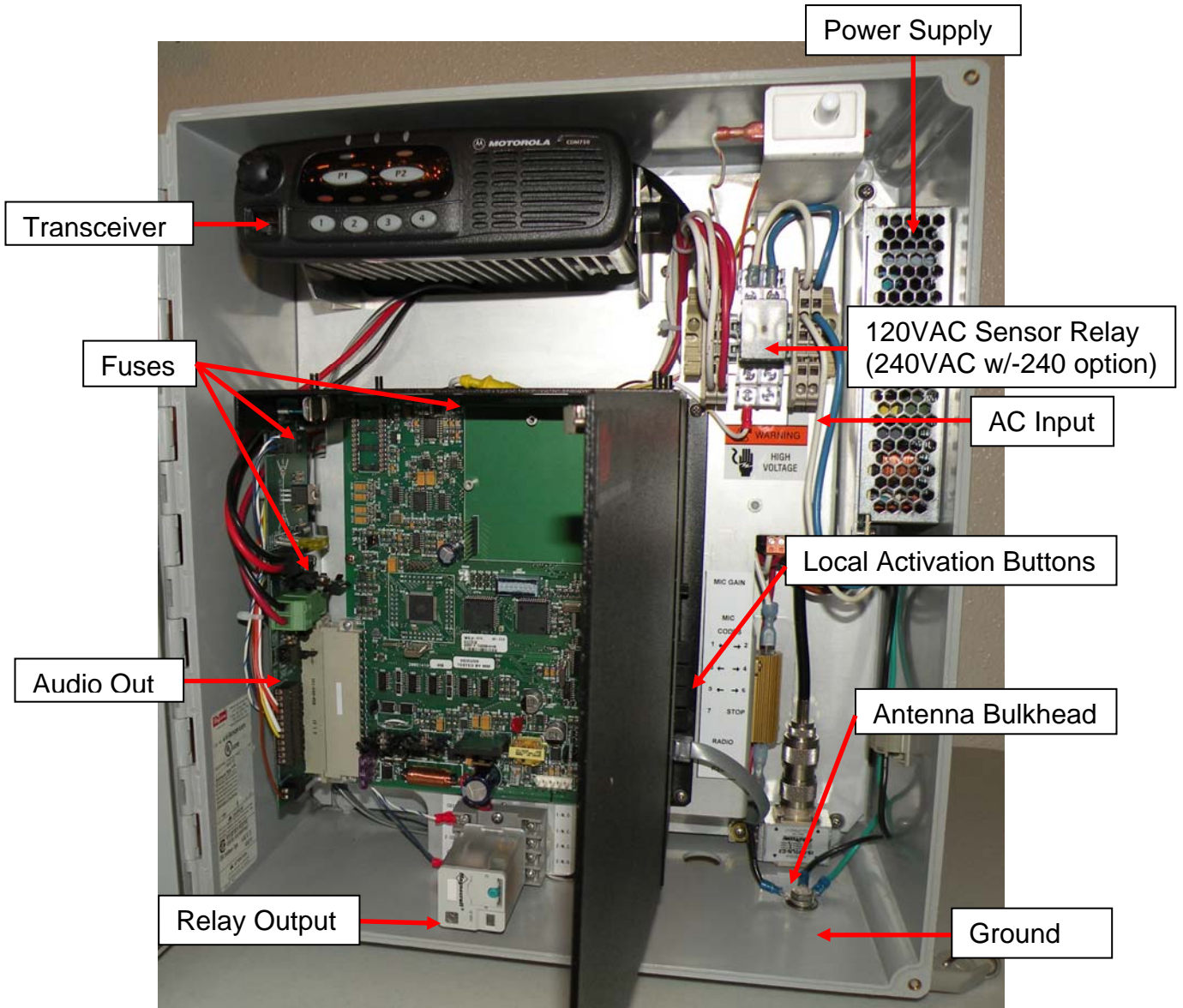

Figure 4.2 - UVRI Parts Layout

4.3 Initial Configuration

Each modular UVRI controller contains the following configuration parameters that must be initially configured. Additional programming configuration is required before placing the UVRI into service. Refer to the programming software reference manual for programming information.

1. Unit Type
2. RF Frequency
3. Security Key
4. 128-bit Encryption Key
5. Unit Address (see below)
6. Configuration Jumper Settings

4.3.1 Unit Type

The UVRI unit type is used to tell the front-end control system how to communicate with the UVRI. This is configured within the Federal Commander software and sent to the UVRI.

4.3.2 RF Frequency

The radio transceiver must be programmed with the RF frequency(s), channel spacing and power output before placing into service. These settings will be pre-set at the factory if the requirements are provided with the order.

If a 1-way radio receiver is used with the UVRI, the RF frequency must be configured using Federal Signal configuration software and sent to the UVRI to put the receiver on the correct RF frequency. The frequency must stay within the correct RF band for the model purchased. The receiver will need re-alignment if the frequency is changed from the factory provided setting.

4.3.3 Security Key

The Security Key is a unique number assigned to the system that prevents nearby systems operating on the same RF frequency from interfering. Like the 128-bit encryption key, the Security Key is programmed during the flashing of the microprocessor and must match the key used at the control point. All sites in the system must use the same security key. The exception is a key value of 65535 (the default), defined as an “open” system and will communicate with all encoders regardless of the encoder’s key setting.

4.3.4 128-bit Encryption Key

128-bit data encryption provides security against malicious operation or monitoring. The 128-bit key is programmed during the flashing of the microprocessor and must match the encoder (SS2000D or SFCDWARE) being used to activate the unit. A key value of zero disables 128-bit encryption and must be used if the encoder does not support 128-bit encryption. All sites in the system must use the same encryption key.

4.3.5 Unit Address

Site Address Switch:

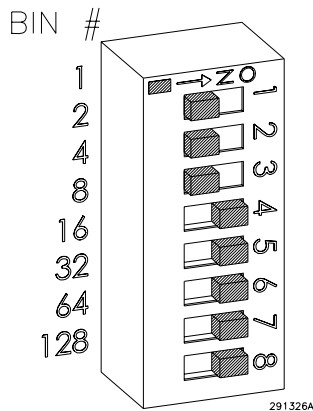

The unit address sets the UVRI site number and is used to numerically identify the site within the system network. The Unit Address is a three-digit number with a range of 001-255. The unit address is set via dip switch S1. S1 Off position indicates active position. Add binary active switch positions to get ID address.

Switch number	1	2	3	4	5	6	7	8
Binary number	1	2	4	8	16	32	64	128

Example: The illustration above shows Switch numbers 1, 2 & 3 in the active position. The switch in the example above represents the binary numbers 1, 2 & 4, which when added, would equal unit address 7.

Note: The address must be set to address (one) to program a controller board to program a DTMF, non-digital unit. When the programming is completed, change the dip switch setting to the actual site address. Programming details are in The Commander software manual. The site address is stored when power is applied to the controller. If

Federal Signal UltraVoice
UVRI Installation and Operation Manual

the site address is changed, cycle power to the control board by removing the connector at JP3 on the motherboard for five seconds.

4.3.6 Control Board Configuration Jumper Settings

JP4 - Battery Charger Sense:

- Jumper out = Default Setting

JP5 - Short to force radio Carrier Detect

- Jumper out = Default Setting

JP14 - External Transceiver VOX Carrier Detect (Audio level dependent Carrier Detect)

- Jumper OFF = VOX Disabled (Default setting)
- Jumper ON = Carrier detect in < 20mS when received audio exceeds 15% deviation.

JP9 - Dual receiver priority jumper:

- Jumper "EXT" side to give external receiver priority
- Jumper "INT" side to give on-board receiver priority
- Jumper neither side, first carrier detect has priority

JP13 – Audio Output

- Jumper TXAud, pins 2 and 3 Default Setting

Federal Signal UltraVoice
UVRI Installation and Operation Manual

4.3.7 User Programs

The UVRI has the capacity to store up to fifty (50) user programs. Each user program contains the following elements:

- 1) Optional DTMF Activation Code
- 2) Optional Two-Tone Activation Code
- 3) Optional EAS Event Code
- 4) POCSAG code
- 5) Digital activation Code
- 6) List of up to 20 functions

The ability to assign more than one function to each activation code or user program is a new feature not previously found in electronic sirens. This allows the user to run a sequence of functions without sending additional activation commands, greatly enhancing flexibility while reducing operator involvement and communication channel traffic.

4.3.8 Available Functions:

Arm
Disarm
Report
Master Reset
Cancel
PA Output
Quiet Test
Low Power Mode
Hi Power Mode
Zone A (Not used with UVRI)
Zone B (Not used with UVRI)
Zone C (Not used with UVRI)
Zone D (Not used with UVRI)
Wail
Pulsed Wail
Alt Wail
Steady
Pulsed Steady
Alt Steady
Auxiliary (Chime)
Delay
Digital Voice (1-16)
Amp/Audio Zone Control (Not used with UVRI)

Federal Signal UltraVoice
UVRI Installation and Operation Manual

Power
Report
Record PA Message
Play Recorded PA Message
RelayN On (Not used with UVRI)
RelayN Off (Not used with UVRI)

4.3.9 Low Power Mode, Hi Power Mode

This causes the siren to operate at a greatly reduced volume level. Upon activation of a user program, the siren defaults to Hi (normal) volume level. This command must follow an ARM command. Reduced volume mode will remain in effect for all subsequent functions in a user program that follow the Low-Power function or until a Hi-Power function occurs or an ARM command is sent.

4.3.10 Delay

The delay function causes the siren to pause (wait) for 2 - 512 seconds before starting the next function of the user program currently running. When selecting the delay function, the user will be prompted to enter the desired delay time in seconds. A default delay of 4 seconds is present between functions, without adding a delay.

4.3.11 Power Level

The Power function allows the user to control the volume level. The volume can be adjusted from 0 to -20 dB in 1 dB steps. Reduced volume mode will remain in effect for all subsequent functions in a user program that follow the Power function, or until another Power function occurs, or an ARM command is sent.

4.4 Programming Methods

There are two methods of entering and reviewing the user programming information in an UltraVoice electronic siren controller:

1. FSPWARE Windows^R based programming software for 2-tone and DTMF controlled systems. This software requires a direct connection between the siren and the computer's RS232 port.
2. SFCDWARE Windows^R based digital control and status monitoring software. This software may be used over a landline or wireless radio channel as well as over an RS232 port.

Detailed information on the operation of the WINDOWS^R program is beyond the scope of this document and can be found in the software's Help file.

4.5 Status Monitoring:

The UVRI monitors various diagnostic conditions for reporting back to a central monitoring station using optional control and status monitoring hardware and software.

4.5.1 Items monitored

Siren Type
Function State (code running)
Unit ID
Audio A*
Audio B*
Master Current / Remote System Operation*
Battery Voltage
Charger
AC Power
Control Box Intrusion
False Alarm/Local Activation*

*Latched Items -- remain set until reception of a Reset command or another function is run.

Status information is transmitted either as a DTMF or FSK data string over the communications channel and as an ASCII string over the RS232 port. Report back transmission will occur when one of two conditions exist:

1. Reception of a REPORT command or
2. One of the asynchronous status conditions changes state.

GENERAL DESCRIPTION

5 SPECIFICATIONS

5.1 Electrical

Battery Voltage	10-14 Vdc, 13.7 volts (nom.)
Battery Current	< 80 mA. standby current, < 120 mA during a function <7A during radio transmit
Stand By Time (with minimum 5-minute full signal reserve)	Greater than 24 hours (With CDM750 transceiver, 10W, 8 Tx / day)

5.2 Power Supply

AC Input	88-264VAC, 50-60 Hz,
Input Current (115/230 VAC)	2.2/1.2 A
DC Output	13.5-16.5VDC (14VDC Nom.), 7A
Immunity	IEC61000-4-2,-3,-4,-5,-6,-8,-11
Conducted/Radiated EMI	EN55011/EN55022-B, FCC-B
Terminal Block Wiring	14-22 AWG
Terminal Block Torque	1-1.4Nm torque

Federal Signal UltraVoice
UVRI Installation and Operation Manual

5.3 Battery

Rating:	12V, 12A/H
Type:	PowerSonic PS12-120I Absorbed Glass Matt Valve Regulated Lead Acid (AGM - VRLA)

CAUTION: Substituting batteries may be hazardous and will void warranty. Use specified batteries only.

5.4 Relay Output

Contacts	DPDT, 28 VDC, 277VAC, 12A
----------	---------------------------

5.5 Control Board (2005141-05)

5.5.1 Serial & I2C Ports

Serial Port Protocol	RS232C 1200,N,8,1
I ² C Port Protocol	Philips Standard I ² C

5.5.2 Signaling Formats

Number of codes	Up to 50 activation codes maximum
Number of Functions allowed stacked under each code	Up to 20
Two-Tone Sequential or Single Tone	282 Hz – 3000 Hz 0.5 sec (A) - .25 sec (B) minimum to 8 sec maximum
DTMF	3 to 12 digits standard 50 ms/50 ms timing or greater
FSK	
Baud rate	1200 bps
Modem type	MSK (minimal shift key)
Mark frequency	1200 Hz
Space frequency	1800 Hz
Error checking	16 bit CRC

SPECIFICATIONS

Federal Signal UltraVoice
UVRI Installation and Operation Manual

I ² C	5 volts peak-to-peak +/- 1 volt input 5 volts DC +/- .2 volts 250 mA Ground 250 mA maximum sink
RS232 Serial Port	RS232 standard, 1200 baud,N,8,1

5.6.3 Manual Activation Switches:

QTY 8, activate with a hold time >0.50 seconds

5.6.4 Indicators:

RXD	Receive Serial Data & receipt of radio channel modulation
TXD	Transmit Serial Data & DTMF & Digital
AUDIO A	Audio present on Channel A
AUDIO B	Audio present on Channel B
ARM	Unit Armed indicator
PA	Public Address mode indicator
CPU	Microprocessor Heartbeat
CARRIER	RF Carrier indicator on w/carrier present

SPECIFICATIONS

Federal Signal UltraVoice
 UVRI Installation and Operation Manual

5.6.5 Control Unit Connector Configuration

Refer to tables below for description of connectors in control assembly.

Connectors for 2005141-05 PCB	
CONNECTOR DESIGNATION	PURPOSE
JP1	On-Board Receiver Module Connector Pins: 1 Ground 2 +8V 3 Clock 4 Data 5 Latch Enable 6 Carrier Detect Not 7 De-Emphasized Receive Audio 8 Flat Receive Audio
JP2	Inter Board Connections
JP3	SINAD Pin 1: Ground Pin 2: SINAD
JP4	Battery Charger Sense: -Jumper out: used with battery charger Pass on >3 VDC @JP20-2 -Jumper in: used with solar, Pass on 1 VDC less than battery voltage @JP20-2
JP5	Short to force Carrier Detect 1 Carrier Detect 2 Ground
JP6	External Radio Connector Pins: 1 RX Audio In 2 TX Audio Out 3 Carrier Detect 4 PTT 5,7 12 VDC for Radio 6,8 Ground

SPECIFICATIONS

Federal Signal UltraVoice
 UVRI Installation and Operation Manual

Connectors for 2005141-05 PCB – Continued	
CONNECTOR DESIGNATION	PURPOSE
JP7	CTCSS Connector Pins: 1 RX Audio In 2 Ground 3 8 VDC for CTCSS Board 4 Audio Switch 5 TX CTCSS Tone
JP8	600 Ohm Configuration Jumper -See motherboard JP15 and JP12 Pins: Jumpered is active 2-3 Activation audio from JP12 1-2 PA mode - External audio source at JP12 - Level adjusted by R111
JP9	Receiver Priority Pins: 1-3 External Receiver Priority 2-4 Internal Receiver Priority
JP10	Digital Disable Jumper Pins 1-2 to disable Digital Decoder
JP11	SINAD Jumper Pins 1-2 to enable SINAD board Note: JP9 must have both 1-3 & 2-4 jumpered when SINAD is used
J1	Microphone Jack Tip Audio In Ring PTT Sleeve Ground

SPECIFICATIONS

Federal Signal UltraVoice
UVRI Installation and Operation Manual

5.7 Motherboard (2005320)

JP1 – Relay Output Control	1A, 30VDC
1 - ground	
2 - switched 10 - 15 Volts	(Switches on when a function is active)
JP2 - Switched Radio Power Output	10A, 30 VDC
1 - ground	
2 - switched 10 - 15 Volts	(Switches on when control board is operating above low voltage cutoff point)
JP3 – 12VDC Power Input	
1 - ground	
2 - 11 - 15 Volts	
JP4 – Audio Signal Output	
1 - ground	
2 - signal	
Output voltage Swing	>4.5V Peak to Peak
Maximum Load	2K Ohms
Total Harmonic Distortion	< 10% w/1KHz Sine-wave
JP5 – Control Board Connection	
JP6 – Sensor Inputs	
1. GND	
2. Activation Detect (SPR#1)	
3. GND	
4. Intrusion	
5. GND	
6. Solar	
7. GND	
8. AC	
9. GND	
10. PTT	
11. GND	
12. Spare (SPR#2)	

SPECIFICATIONS

Federal Signal UltraVoice
UVRI Installation and Operation Manual

JP7 - Audio Channel Select Jumper

- Jumper pins 1 & 2 to select channel A
- Jumper pins 2 & 3 to select channel B

JP8 - Charger Sense Input

- 1 - ground
- 2 - charger input

Fuses

- (F1) Relay Coil @JP1 ATO, 1A, 32 VDC
- (F2) 12 VDC Radio @JP2 ATO, 10A, 32 VDC

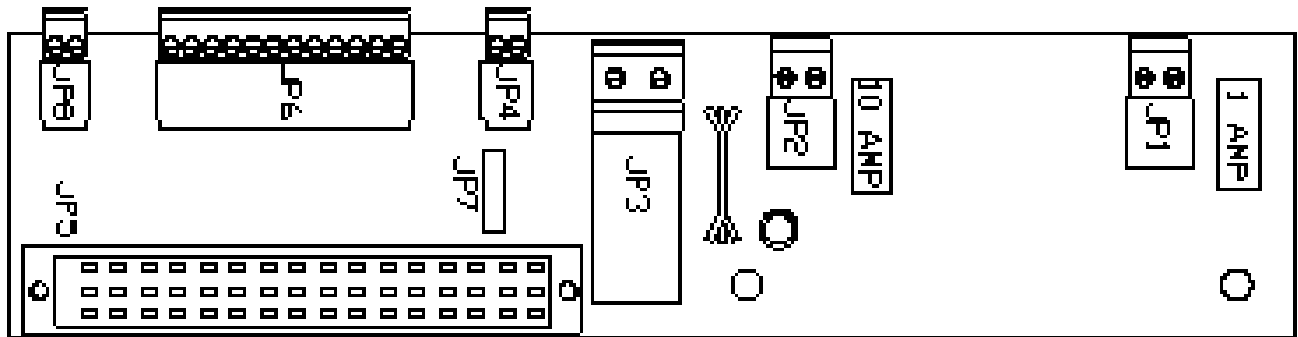

Figure 5.1 - Motherboard Outline Drawing

SPECIFICATIONS

Federal Signal UltraVoice
UVRI Installation and Operation Manual

5.8 Environmental

Operating Temperature	-13°F to 140°F / -25°C to +60°C
Humidity	0-98% non-condensing

Notes:

1. The UVRI can operate throughout this temperature range provided the battery temperature is maintained at -18°C or higher.
2. The UVRI housing carries a NEMA 4X / UL50 rating

5.9 Physical

Enclosure	16"x15"x8-3/8" (HxWxD) [40.64 cm x 38.1 cm x 21.27 cm]
Weight	29.6 lbs / 13.43 Kg (including battery)

SPECIFICATIONS

6 UVRI OPERATION

6.1 Hardware General Description

All relay control, audio generation and remote communication functions are handled by a single microcontroller board. The back-plane (motherboard) contains connectors and terminal blocks for interconnection to other system components.

The UVRI receives remote control signals and responds to the Federal Commander remote monitoring system to provide live and recorded voice, warning tones, and a remote control relay contact output. The UVRI provides a contact closure to activate the remote system and provide an audio output at JP4 on the motherboard.

Operation is supervised and status information is transferred back to the control station(s) via one or more available communications networks. The UVRI monitors the audio output level and the Remote Activation input on the motherboard at JP6-2 to verify proper operation. Remote Fire Alarm and PA systems provide a contact closure across JP6-1 and JP6-2 to indicate proper operation.

The controller can be powered from 12VDC and/or 120 or 240 VAC.

6.2 Manual Activation

The manual activation switches located on the face of the controller are used to manually activate siren functions.

Function Switch	Function
FUNC1	Activates Functions under code 1
FUNC2	Activates Functions under code 2
FUNC3	Activates Functions under code 3
FUNC4	Activates Functions under code 4
FUNC5	Activates Functions under code 5
FUNC6	Activates Functions under code 6
FUNC7	Activates Functions under code 7
FUNC8	Reset
FUNC5 & FUNC7	Digital Transmit Deviation tone

NOTE: At any time during a sounding function the "RESET" button may be pushed to cause the unit to halt all output immediately.

6.3 Local Public Address

The operator has the ability to give local Public Address (PA) messages using the model MNC-MC microphone provided. PA mode can be entered simply by pressing the push-to-talk (PTT) button on the MIC while the MIC is plugged into the 1/4" receptacle on the front panel. The PA LED will be lit anytime the PTT button on the microphone is pressed. The local PA volume level is set by adjusting the MIC GAIN knob located directly above the MIC jack.

NOTE: Local PA overrides ALL siren functions activated either remotely or locally.

6.4 Relay Output

A DPDT relay output is located in a socket at the bottom of the control cabinet. This relay closes whenever a alert tone, digital or live voice message is active and can be used to trigger remote devices.

6.5 Sensor Inputs

Terminal block JP6 on the motherboard accepts contact closure inputs. These inputs are activated by a short to "Common".

Sensor Connections

JP15 Terminal	Function
1	"Common"
2	Remote Activation "Spare #1"
3	"Common"
4	"Intrusion"
5	"Common"
6	"Solar"
7	"Common"
8	"AC Power"
9	"Common"
10	"600 PTT"
11	"Common"
12	"Spare #2"

Federal Signal UltraVoice
UVRI Installation and Operation Manual

6.5.1 Intrusion

Alerts the controller when one of the unit's doors has been opened.

6.5.2 Solar: Used to sense operation of solar power system.

Jumper JP15: pins 5 to 6 and to enable solar sensing. Solar mode latches power sense to prevent low light conditions from causing failures. For solar panel test, initiate a reset, and then a poll. Immediate good power input required after a reset to pass.

Jumper JP15 pins 7 to 8 AC sense is required if solar only unit.

6.5.3 Spare#1

Remote system operation detect. Shorting this input verifies that the remote system is active.

6.5.4 Spare #2

Unused inputs for special functions.

6.5.5 AC Power

Alerts the controller when the AC Power has failed. Open is fail. Closed is pass.

6.5.6 600 Ohm PTT

Puts the unit in Local PA mode for input of external audio. Closed is active

6.6 Two-Way Status Monitoring

The UVRI uses a variety of sensors in the UVRI Series Controller, which when equipped with a two-way radio, allows the remote unit to communicate its status back to the base station. This reduces station downtime by quickly alerting operating personnel to potential problems at remote units.

The following status points are monitored:

1. AC Power (AC sense relay)
2. Battery Voltage (built in)
3. Charger Operation (built in)
5. Signal A (built in)
6. Signal B (built in)
7. Remote System Operation (Motherboard JP6-1&2)
8. Intrusion

6.7 Quiet Test

This option enables acoustically quiet tests to be performed on the UVRI control and the remotely controlled devices. Quiet Test uses a 20 kHz tone to quietly test the tone generators and the remote amplifiers (if applicable). To perform this test the Quiet Test must be programmed under one of the activation codes. If it is one of the first 7 codes then it can be activated manually through the switches on the front panel or with the remote activation inputs. Normally once the Quiet Test is programmed under one of the activation codes, the code is activated over the radio channel, the panel switches, or with a local laptop computer running SFCDWARE.

A. Operation

The results of a Quiet Test can be obtained remotely using the SS2000 printout or the SFCDWARE control and status monitoring software. The status can also be obtained locally at the siren site with a portable computer running SFCDWARE. The actual amplifier voltage and current are monitored with Quiet Test providing a true indication of each amplifier and load performance.

B. Finding Faults

When using SFCDWARE, the controller will automatically update the Quiet Test status each time a new Quiet Test is run. The status can be obtained from the status detail screen and from the Reports menu.

6.8 DC Power Supply

A 13.5-16.5VDC (13.8VDC Nom.), 7A supply provides a constant voltage current limited charging system for the integrated 12V battery and power for peripheral equipment.

7 SYSTEM PLANNING

7.1 Control Unit

Select a suitable mounting location that is secure, and away from high voltage wiring and high power RF systems. The Control Unit can be mounted indoors or outdoors depending on what equipment it will be connected to as long as the unit is kept within the operating temperature limits.

Refer to the specification section to obtain the weight of the UVRI. Insure that the mounting surface and fasteners can safely sustain the weight of the assembly.

In order to reduce the possibility of introducing noise in the audio path, the controller should be placed as close as possible to the Fire Alarm or remote PA system.

The controller should be located out of the reach of vandals. The controller is supplied with padlock hasps that will accept user provided padlocks for security.

The UVRI requires a 120 VAC or 240 VAC 50-60 Hz power source to power the UVRI and charge the internal 12V battery.

Several methods can be used to activate the Control Unit. Plan how the UVRI will be connected to the antenna system or wired communications network.

If radio control is going to be used, consider RF coverage and antenna placement when selecting a suitable location.

8 INSTALLATION

WARNING

Read all Safety Notices at the beginning of this manual before installation.

This section contains reference drawings to assist with installation. A list of typical installation materials required may be obtained by reviewing the cabinet mounting details and the electrical installation material list below.

8.1 UVRI Controller Installation Reference Drawings

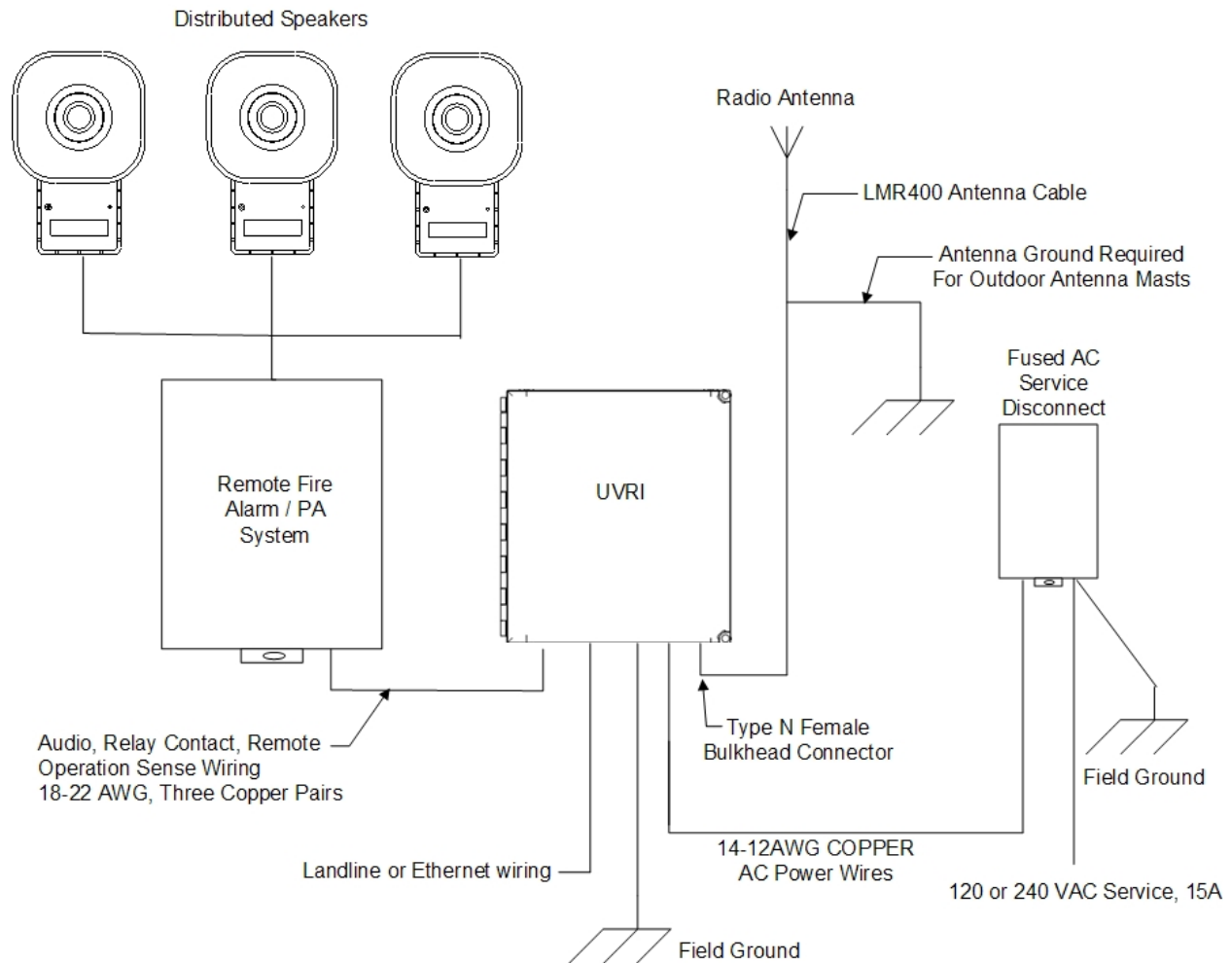
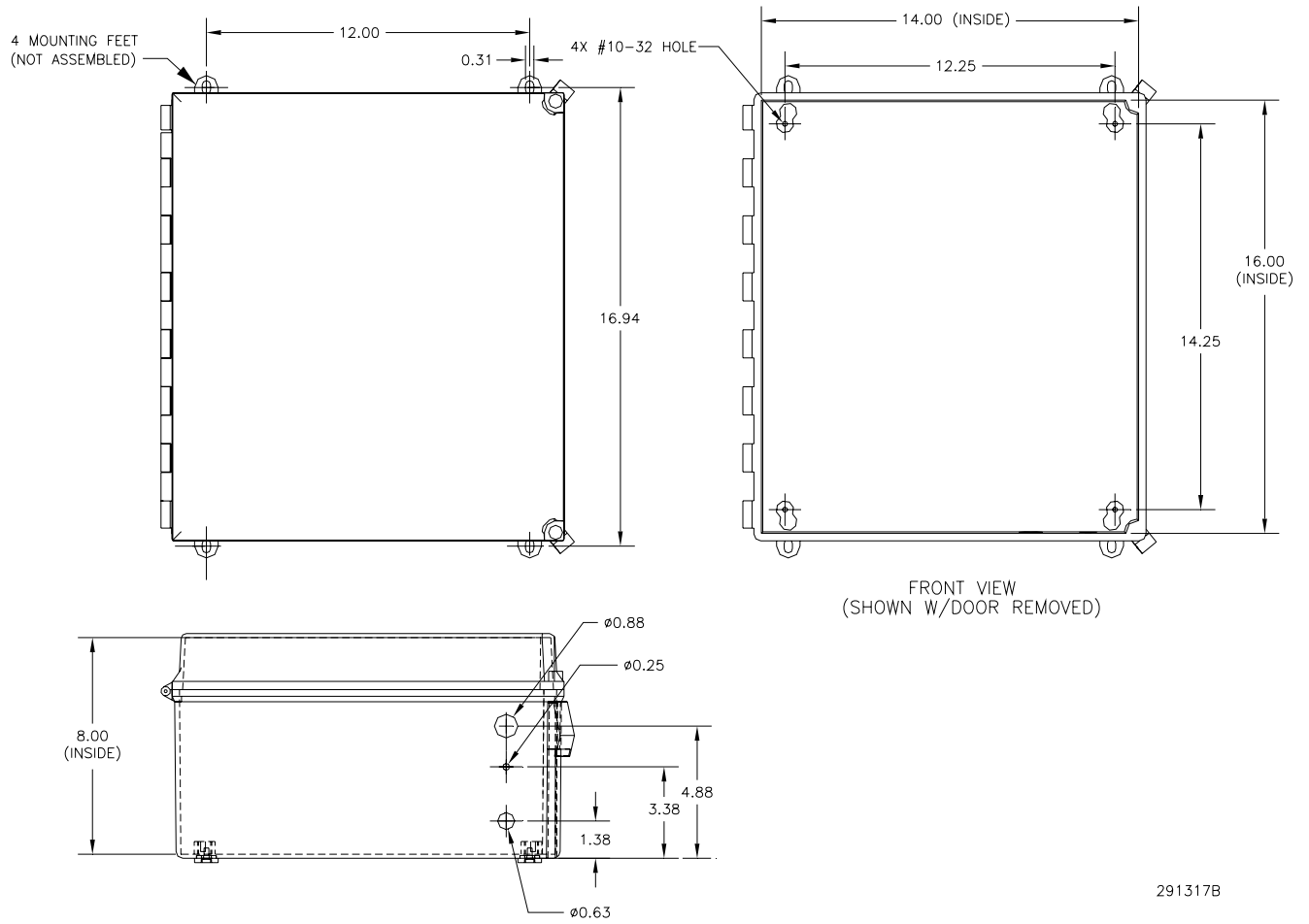

Figure 8.1 - Typical UVRI Installation Drawing

Federal Signal UltraVoice UVRI Installation and Operation Manual



291317B

Figure 8.2 - UVRI Cabinet Dimensional Outline Drawing

Federal Signal UltraVoice UVRI Installation and Operation Manual

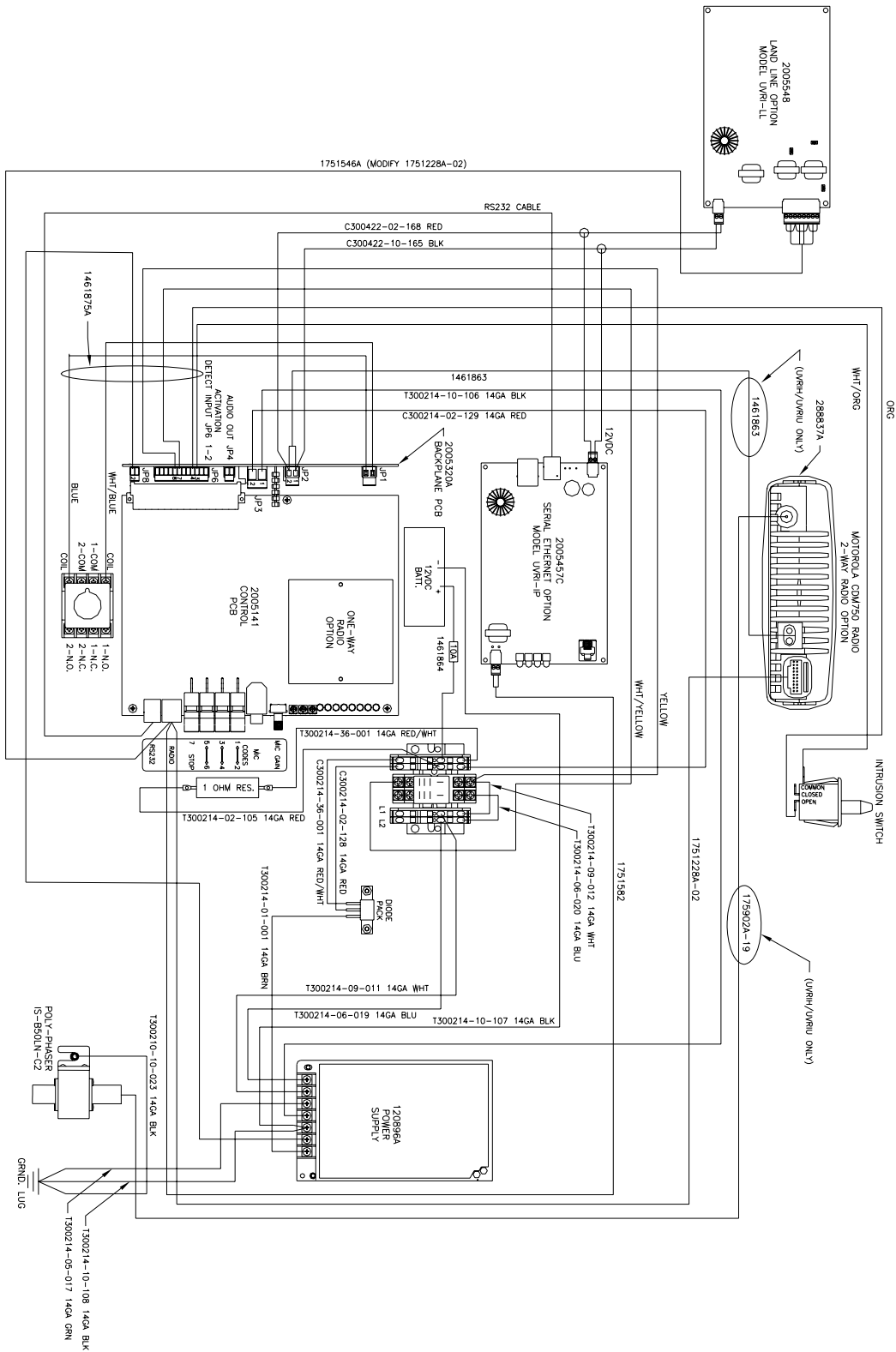

Figure 8.3 – UVRI Wiring Diagram

8.2 General Mounting Guidelines

These general installation instructions are pertinent to all installations. Specific mounting methods and required installation materials are described in the next section.

1. There are four cabinet mounting flanges available for bolting the UVRI to a flat surface, (see *Figure 8.2*).
2. The total weight of the UVRI is listed in the specifications section. It is imperative that the mounting surface and mounting method selected can safely sustain the weight of the assembly.
3. Prepare the mounting surface for hanging the cabinet by predetermining the location of the mounting holes. The cabinet should be attached to a wall or other substantial vertical surface using the four mounting flanges. Lag bolt the cabinet to the wall using the prepared holes and anchors.
4. If the UVRI model being installed has a 2-way radio, ensure the radio antenna cable is installed before applying power to the UVRI to avoid damaging the radio.

8.3 UVRI Installation Material List and Installation Guidelines

The following material lists and guidelines describe basic installation details required to install the UVRI cabinet. This list will vary depending on mounting methods, other options, local and national electrical codes, etc. Therefore, this list should be used as a reference guideline only.

Concrete or Filled Cement Block Wall Mounting Materials		
Material Description	Purpose	Qty
1/4" x 2" Pin/Sleeve/ Lock Washer/Nut Style Anchors	Anchor Bolts	4

8.3.1 Concrete or Filled Cement Block Wall Mounting Guidelines:

1. Mark the mounting hole locations on the wall for the cabinet.
2. Install the anchor bolts for the four cabinet corners according to the manufacturer's instructions.
3. Mount the cabinet to the wall.
4. Proceed to following section.

Note: If wall is not straight, use shims to insure enclosure maintains square and structural integrity.

Hollow Block Wall Mounting Materials		
Material Description	Purpose	Qty
1/4" x 2" Heavy Duty Toggle Bolts	Anchor Bolts	4

8.3.2 Hollow Block Wall Mounting Guidelines:

1. Mark the mounting hole locations on the wall for the cabinet.
2. Install the anchor bolts for the four cabinet corners according to the manufacturer's instructions.
3. Mount the cabinet to the wall.
4. Proceed to following section.

Federal Signal UltraVoice
UVRI Installation and Operation Manual

Wood Stud Wall Mounting Materials		
Material Description	Purpose	Qty
1/4" x 1" Lag bolts	Backboard & cabinet mounting bolts	8
2' x 2' x 3/4" B/C or better plywood	Mounting backboard	1
Construction adhesive	Mounting backboard attachment	1

8.3.3 Wood Stud Wall Mounting Guidelines:

1. Locate the wall studs for attaching the mounting backboard to the wall. The backboard should attach to at least two studs.
2. Mark the wall stud location on the mounting backboard and drill four pilot holes for the lag bolts.
3. Apply construction adhesive to the back of the mounting backboard.
4. Attach the mounting backboard to the wall with four lag bolts.
5. Locate the mounting position of the cabinet on the mounting backboard.
6. Drill pilot holes for the lag bolts.
7. Mount the cabinet to the mounting backboard.
8. Proceed to the following section.

Federal Signal UltraVoice
UVRI Installation and Operation Manual

Metal Stud Wall Mounting Materials		
Material Description	Purpose	Qty
1/4" x 2" lag bolts	Cabinet mounting bolts	4
2' x " x 2' B/C or better plywood	Mounting backboard	1
#14 x 2" metal stud screws	Backboard mounting	6
Construction adhesive	Backboard mounting	1

8.3.4 Metal Stud Wall Mounting Guidelines:

1. Locate the wall studs for attaching the Mounting Backboard to the wall.
2. Mark the wall stud location on the mounting backboard and drill pilot holes for the #14 metal stud screws. Three screws should be placed in each stud evenly spaced apart.
3. Apply construction adhesive to the back of the mounting backboard.
4. Attach the mounting backboard to the wall with #14 metal stud screws.
5. Locate the mounting position of the cabinet on the mounting backboard.
6. Drill pilot holes for the 1/4" lag bolts.
7. Mount the cabinet to the mounting backboard.
8. Proceed to the following section.

Federal Signal UltraVoice
UVRI Installation and Operation Manual

8.4 Installer Supplied UVRI Electrical Installation Material List

Material Description	Purpose	Qty
30 amp/250V/ 2 Pole Solid Neutral/Fused Disconnect w/ Ground Kit/ NEMA 1 Rating/ Lockable Cover Tang/ Lockable Operator	Optional Electrical Disconnect	1
10A FRNR Fuse	Fuses For 120V Service	1
5A FRNR Fuse	Fuses For 240V Service	2
12 - 14 AWG White Wire	AC Neutral from disconnect	8'
12 -14 AWG Black Wire	AC Load from disconnect	8'
12 -14 AWG Green Wire	Equipment ground from disconnect	8'
1/2" Seal Tight Conduit & Fittings	Electrical conduit from disconnect and to Fire Panel/PA System	Varies
Metal Ground Bushings	Equipment ground connections	2
Screws, appropriate to mounting surface	Disconnect mounting	4
15A Breaker	Service panel breaker serving unit	1
White Wire appropriately sized	AC neutral from breaker panel to disconnect	Varies
Black Wire appropriately sized	AC load from breaker panel to disconnect	Varies
Green Wire appropriately sized	Equipment ground from breaker panel to disconnect	Varies
Conduit & fittings, appropriately type and size for particular installation requirements	Electrical conduit from breaker panel to disconnect	Varies
6 AWG Stranded	Cabinet ground to earth ground for external antenna applications	Varies
18-26 AWG stranded wire pairs	Audio, Relay Output, and Remote System Operation Sense	Varies

8.5 Electrical Connections

Make all electrical connections in compliance with local electrical codes and NEC recommendations. Disconnect all power and read all warnings at the beginning of this manual and on the batteries before making connections.

8.5.1 Grounding Requirements

1. The UVRI cabinet must be properly connected to an earth ground. The cabinet contains an external 1/4" ground stud for making this connection.
2. Externally installed antennas require a dedicated ground to either a ground rod or building steel *below* grade in addition to the UVRI cabinet ground.

8.5.2 AC Power Connections

Caution

Verify the AC voltage requirement for the UVRI model being installed. 240 VAC versions of the UVRI controllers have a "-240" suffix in the model number shown on the label located on the cabinet door. All other UVRI models are to be wired to 120 VAC.

8.5.3 DIN Rail Terminal Blocks

These points provide a convenient location for making the AC power connections. A small screwdriver must be pushed into the square opening in the terminal block to open the contact of the block. With the wire inserted, the block will clamp the wire with a spring-loaded connection when the screwdriver is removed from the terminal block.

Each terminal block accepts bare 12-14 AWG wire. The terminal blocks are labeled L1 and L2.

8.5.4 120 VAC Electrical Service Wiring

1. Install a dedicated 15A circuit breaker in an existing breaker panel or install a new breaker panel if necessary for the UVRI.
2. Install conduit from the breaker panel to the 1/2" conduit entrance in the bottom of the UVRI.
3. Route user-supplied 12-14 AWG wires (1 black, 1 white, 1 green) through the conduit from the UVRI Cabinet and the fused breaker panel.
4. Connect the white neutral wire from the breaker panel neutral to the DIN rail mounted terminal block labeled L1 in the UVRI control cabinet.

Federal Signal UltraVoice
UVRI Installation and Operation Manual

5. Connect the black line wire from the 15A breaker to the DIN rail mounted terminal block labeled L2 in the UVRI control cabinet.
6. Optionally, connect a green ground wire from the breaker panel earth ground to the green ground block in the UVRI cabinet or run a ground lead from the external 1/4" ground stud on the UVRI cabinet to earth ground.

8.5.5 240VAC Electrical Service Wiring

1. Install a dedicated 2-pole 15A breaker in an existing breaker panel or install a new breaker panel if necessary for the UVRI.
2. Install conduit from the breaker panel to a conduit entrance in the bottom of the UVRI. Ensure the conduit is adequately grounded.
3. Route user-supplied 12-14 AWG wires (2 black, 1 green - optional) through the conduit from the UVRI Cabinet and the fused breaker panel (or as otherwise specified by code).
4. Connect one line wire from the 15A breaker panel to the DIN rail mounted terminal block labeled L1 in the UVRI control cabinet.
5. Connect the other line wire from the 15A breaker to the DIN rail mounted terminal block labeled L2 in the UVRI control cabinet.
6. Connect a green ground wire from the breaker panel earth ground to the green ground block in the UVRI cabinet or run a ground lead from the external 1/4" ground stud on the UVRI cabinet to earth ground.

8.5.6 DC Power Connection

The battery is located under the control board mounting plate and is pre-wired to the UVRI. Connect DC power to the UVRI by plugging in the two position power connector at JP3 on the motherboard as shown in figure 8.5 below.

8.5.7 Audio Output Connection

Connect the audio output of the UVRI to the audio input of the Remote Fire Alarm/PA System at JP4 on the motherboard as shown in figure 8.5 below. Adjust the Audio Output Level potentiometer to the desired output level. The pot is located next to the Audio Signal Output connector (JP4).

8.6 Remote System Sense Input

Connect the remote system sense contact closure to the UVRI to JP6 on the motherboard as shown in figure 8.5 below. This contact is used by the UVRI to report the operational status of the remote system

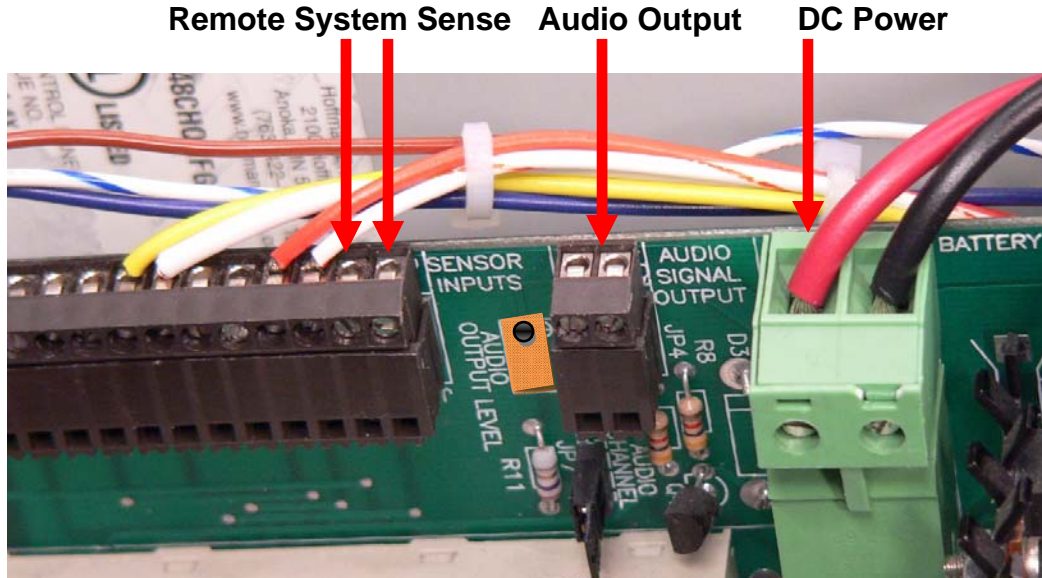

Figure 8.4 – UVRI Remote System Sense, Audio Output and DC Power Connections

8.6.1 Relay Output

The relay output is used to activate the remote Fire Alarm/PA System if a remote contact closure input is available in the remote system. The relay can also be used to control other remote devices such as strobe lights. Two sets of normally open and normally closed contacts are available as shown in figure 6 below.



Figure 8.5 – Relay Output

8.7 Landline Control Connection

If the UVRI-LL wireline control option is used, connect the telephone wire pair from the TB-LL base line driver to the Landline Interface module located in the control cabinet on top of the control board's protective metal cover. Refer to the Telco Interconnect System manual 255377 for further installation details.

8.8 Ethernet Connection

If the UVRI-IP Ethernet control option is used, the UVRI Ethernet module will be located in the control cabinet on top of the control board's protective metal cover. Make the Ethernet connection to J1 on the UVRI Ethernet module. Refer to the Serial to Ethernet User's Guid part number 2005457 for further connection details.

The UVRI requires an IEEE 802.3, 10 Base-T, half duplex connection and uses ports 16,887 (for Codespear TCP/IP) and port 80 (HTTP) for its configuration web page. Ethernet wire runs must be less than 328' from the nearest network switch.

8.9 Antenna Types

Determine type of antenna to be installed if a wireless RF system is used:

1. Cabinet Mounted Magnetic Base
2. Remote Mounted Magnetic Base
3. Yagi External Antenna Type
4. Omni external antenna Type

8.10 Remote Mounted Magnetic Base Antenna Installation

A remote magnetic base antenna may be installed in buildings that a known good RF signal strength inside and a suitable location to mount the antenna.

1. Locate a suitable location for the antenna that is away from any electrical devices, high voltage and computer wiring. The location should be as high as possible and should enable the antenna mast to be at least 2 feet away from any grounded metal objects.
2. Mount the antenna to a flat, secure metal structure with at least 225" square area for the magnetic mount to stick to.

8.11 Yagi Antenna Installation

Yagi Antenna Pre-Assembly

1. Unpack the antenna and locate the following parts:
 - Boom (1-14" for 5 element model, 7/8" diameter for 3 element model)
 - 3/8 diameter elements
 - (y---3 = 3 elements, y----5 = 5 elements)
 - Gamma match parts bag
 - Mounting bracket parts bag
2. Find the proper element dimension chart for your antenna, within the antenna instructions, and trim each element according to your operating frequency. Use care to trim equal lengths from each end of each element ensuring that the mounting hole is at the center.

Note A: Proper trimming and adjustment is critical to the Voltage standing wave ratio, known as VSWR. (Basic understanding, in laymen's terms, for VSWR, reflected power is bad and decreases forward power). (The life of the radio and transmit capabilities is dependent upon the VSWR being low as possible).

Note B: If two frequencies are being used, then trim the antenna to the transmit frequency of the unit where the antenna will be mounted.

3. Insert the elements into their respective locations through the boom, starting with R1 (the reflective element) in the hole closest to the mounting holes. Then insert Dr, D1 etc., in that order.

Note A: Shortest element is furthest away from the mount and increases in size as it gets closer to the mount.

Note B: Be very careful to line up the holes and not cross thread when securing the elements in the next step. The bolts must tighten all the way down upon the lock washers.

4. Secure the elements with the stainless steel 10-32 hex bolts and #10 lock-washers provided.
5. Locate the connector/brass tube assembly in the gamma match parts bag and insert the assembly first through the connector bracket, then thread the connector into the bracket. Be sure to tighten the connector fully. A drop of Loctite or other threadlock may be used in the threads to eliminate the possibility of the connector loosening.
6. Slide the gamma link onto the driven element and assemble the gamma match as shown in figure 1 or 2. Set dimensions "A" and "B" to those shown in table 1. Setting the match to the dimensions shown for your antenna is a good starting point, which will allow you to quickly line tune later. Complete the assembly by attaching the end cap onto the end of the gamma tube. The antenna is now ready for final tuning.

8.11.1 Final VSWR Tuning

1. Before final installation of the antenna, temporarily set it up in a clear area at least six feet above the ground.

Caution

Antennas may cause severe burns. Do not touch the antenna while the radio is transmitting.

Note: Ensure antenna is not touching any conductive material and is pointed away from all objects and people. Pointing antenna at objects in close proximity may act as a reflector and create inaccurate readings.

2. Apply RF power to the antenna at the transmit frequency to be used at that antenna, and check for the low VSWR while performing each of the following steps.
 - A. First, loosen the setscrew with the allen key provided and make a slight adjustment to the aluminum gamma tube for the lowest VSWR (Reflected power).
 - B. Next adjust the gamma link along the driven element for the lowest VSWR.
 - C. Repeat the above steps until the lowest VSWR is achieved. Reflected power must be less than 10% of the forward power.
 - D. Return to the dimensions shown in table 1 if there is any trouble achieving a good match. If the element dimensions are incorrect for the frequency being used, low VSWR may be unattainable. If the VSWR specification is still unattainable, replace the cable (a simple ohm meter check of the cable does not guarantee that the antenna cable is good, due to the DMM not having the ability to check the cable at high frequencies. If that does not take care of the problem, replace the antenna.

8.11.2 Yagi Antenna Mounting

1. See *Figure 8.7* for reference. Install antenna, (using installation bracket or equivalent) as high as possible, that the antenna cable and obstacles will allow, and install on side of mounting structure closest to the receiving station. Aim the antenna directly at the receiving station antenna.

Note A: Objects around the antenna will affect antenna performance. Keep the antenna pointed away from obstructions.

2. Ensure antenna cable connections are tight. Seal all connection points with heat shrink or tape and seal with Scotch Coat or equivalent.

Federal Signal UltraVoice
UVRI Installation and Operation Manual

3. Apply RF power to the antenna at the transmit frequency to be used at that antenna, and check the VSWR (reflected power). Reflected power must be less than 10% of the forward power.
4. If the VSWR specification is unattainable, replace the cable (a simple ohm meter check of the cable does not guarantee that the antenna cable is good, due to the DMM not having the ability to check the cable at high frequencies). If that does not take care of the problem, replace the antenna.

8.12 Omni Antenna Installation

Fiberglass, no tune models

1. See *Figure 8.8* for reference. Install antenna (using installation bracket or equivalent) as high as possible, that the antenna cable and obstacles will allow, and install on side of pole closest to the receiving station.

Note A: Objects around the antenna will affect the antenna, keep antenna away from objects.

2. Ensure antenna cable connections are tight. Seal all connection points with heat shrink or tape and seal with Scotch Coat, or equivalent.
3. Apply RF power to the antenna at the transmit frequency to be used at that antenna, and check the VSWR (reflected power). Reflected power must be less than 10% of the forward power.
4. If the VSWR specification is unattainable, replace the cable (a simple ohm meter check of the cable does not guarantee that the antenna cable is good, due to the DMM not having the ability to check the cable at high frequencies). If that does not take care of the problem, replace the antenna.

Federal Signal UltraVoice
UVRI Installation and Operation Manual

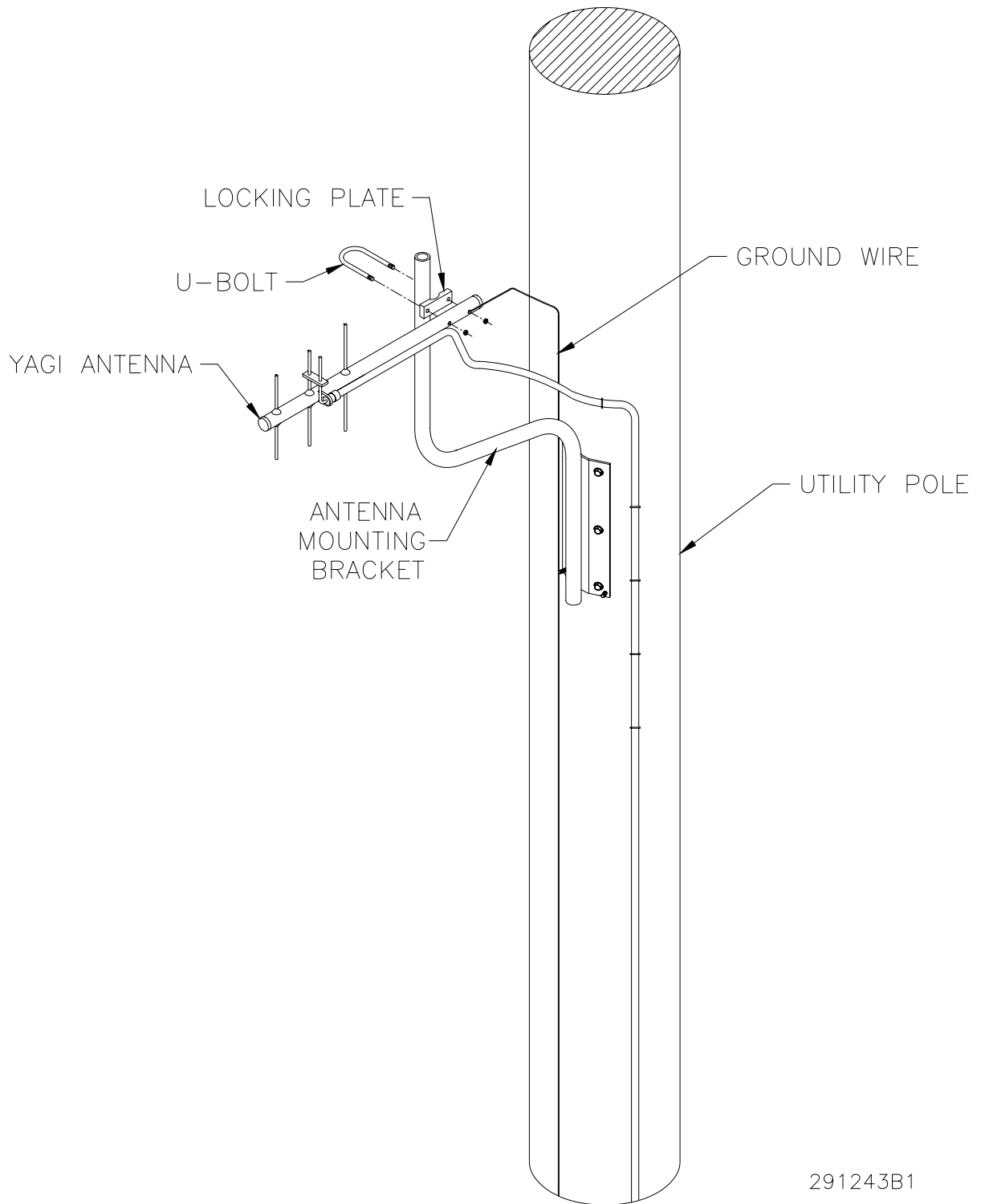

291243B1

Figure 8.6 - Yagi Antenna Installation Example

Federal Signal UltraVoice
UVRI Installation and Operation Manual

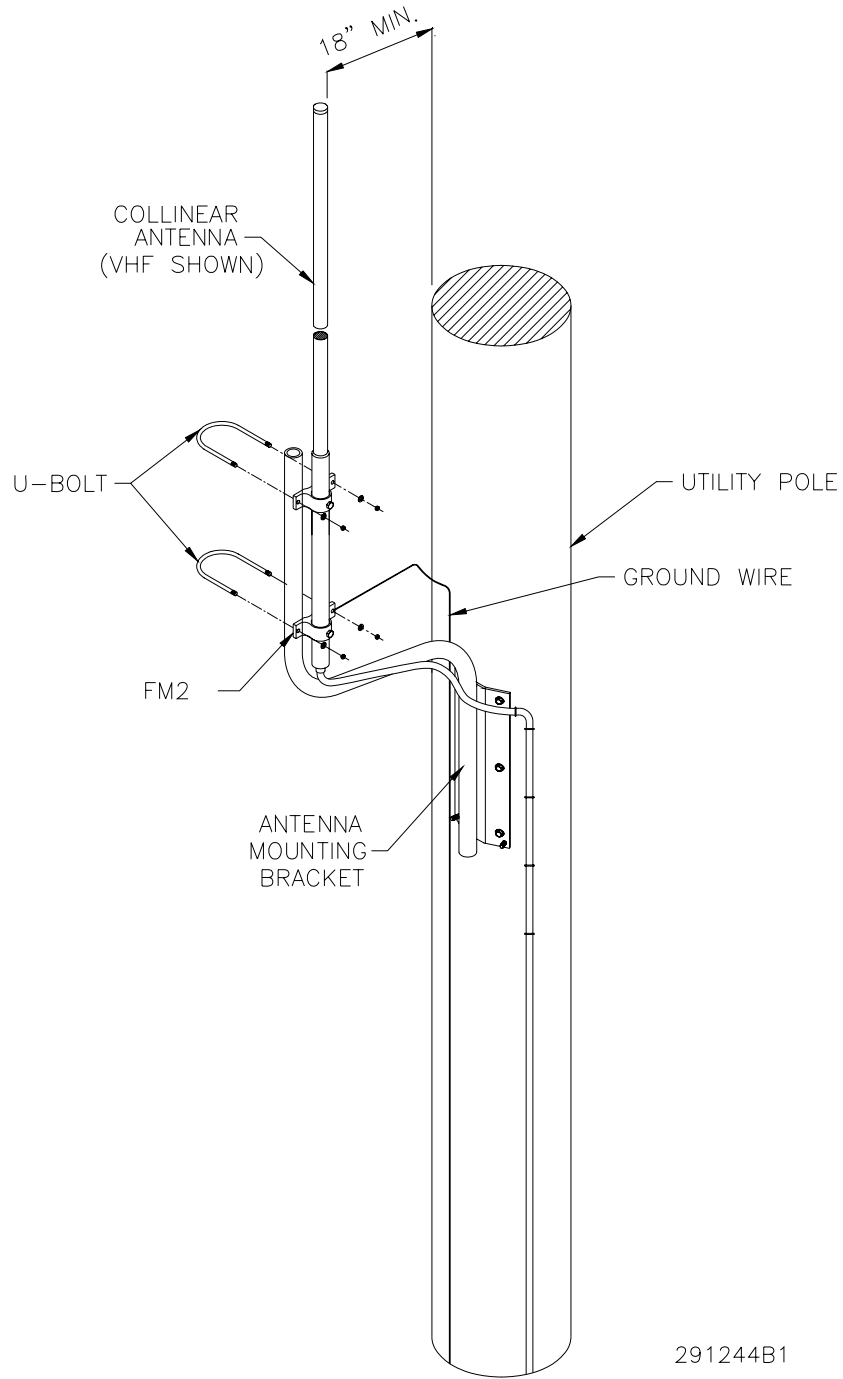
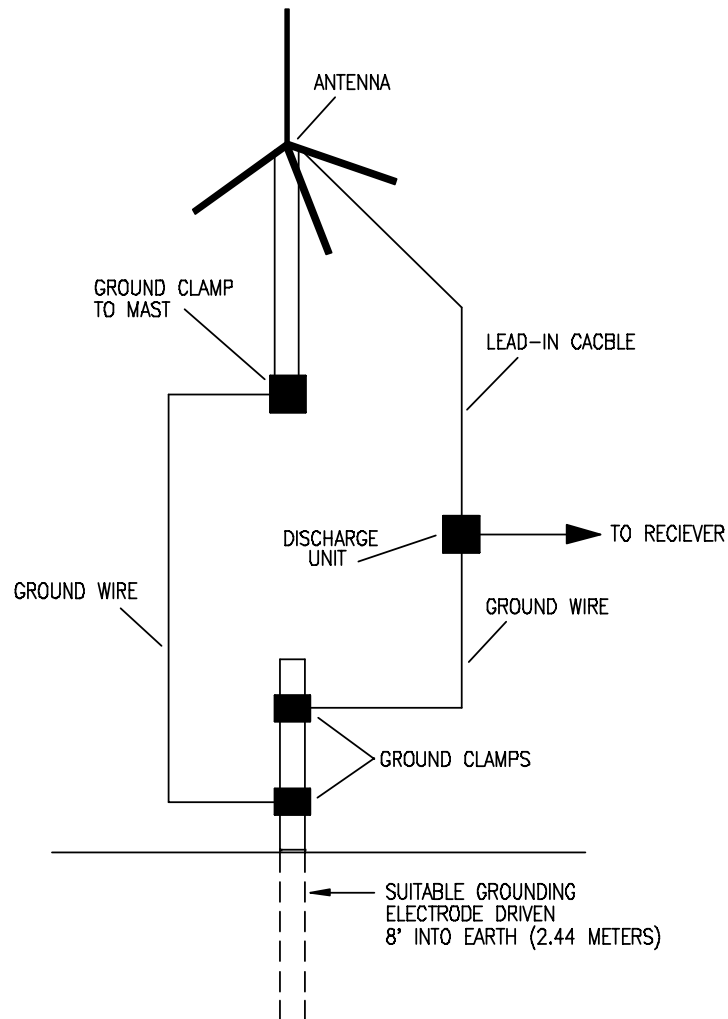

Figure 8.7 - Omni Antenna Installation Example

Federal Signal UltraVoice UVRI Installation and Operation Manual

EXAMPLE OF ANTENNA GROUNDING AS PER
NATIONAL ELECTRICAL CODE INSTRUCTIONS
(REFER TO N.E.C. FOR COMPLETE INSTRUCTIONS.)



- A. USE NO. 10 AWG COPPER, NO. 8 AWG ALUMINUM, NO. 17 AWG COPPER CLAD STEEL OR BRONZE WIRE, OR LARGER AS GROUND WIRE FOR BOTH MAST AND LEAD-IN.
- B. SECURE LEAD-IN CABLE FROM ANTENNA TO ANTENNA DISCHARGE UNIT AND MAST GROUND WIRES TO HOUSE WITH STAND-OFF INSULATORS, SPACED FROM 4 FEET (1.22 METERS) TO 6 FEET (1.83 METERS) APART.
- C. MOUNT ANTENNA DISCHARGE UNITS AS CLOSE TO WHERE LEAD-IN CABLE ENTERS HOUSE AS POSSIBLE.

291160

Figure 8.8 – Antenna Grounding Example

8.13 Turning Power On

1. Once all connections have been made and power is applied, the UVRI control board clock LED will begin to blink (approximately 30-sec. after power has been applied) and the power supply LED will light. The radio transceiver power LED should turn on (if used).
2. Connect AC power and verify that the battery charger LEDs turn on indicating the charger is charging the batteries.
3. Turn on the radio transceiver power (if applicable) and verify the radio power LED turns on.

9 PRE-OPERATION CHECKOUT AND TEST

Warning

The following procedures should be performed by a properly trained technician to ensure the equipment is operating properly.

9.1 Visual Inspection

1. Fill out the Field Test Data Sheet at the end of this section to document the following inspections and tests. The completed document should be kept on file for future reference.
2. Verify all connections and fasteners are tight.
3. Ensure that all installation debris is removed from the cabinet.
4. Secure all wiring with wire-ties to provide strain relief and to neatly manage the wiring.
5. Verify the control board clock LED is blinking.
6. Verify the power supply LED is on.

9.2 Pre-Operation Checkout

1. Refer to *Figure 8.4*. Measure the DC voltage across the DC input connector on the control board. The voltage must be at least 11.5 VDC to turn on the control board. The voltage should be 13.7VDC when AC power is applied to the UVR1.
2. All alert signals and voice messages should be tested at this time. Verify that the correct audio is heard at the proper volume for each function. The Audio A, Audio B, and ARM LEDs should light during each function.

9.3 Radio Transceiver Adjustment Procedure

Note: This procedure previously completed at factory. Only readjust if radio re-alignment is required or if the radio is being installed in the field.

A. Qualifications:

Requires a properly trained Radio Technician.

B. Equipment Required:

1. Service Monitor
2. Oscilloscope

C. Setup:

Connect the radio to the service monitor.

D. Receive Audio Adjustment

1. Using service monitor, modulate the correct RF signal into the receiver with a 1 kHz tone at 3 kHz deviation. If bandwidth is 12.5, then modulate at 1.5 kHz deviation. (If using private line, add 0.75 kHz private line deviation to the signal.)
2. Adjust the level at TP10 (2005141 controller card) for $1V_{p-p}$ using the REC gain adjustment R59 (2005141 controller card front panel).

E. Transmit Deviation Adjustment

1. Simultaneously press buttons 5 & 7 on the 2005141 controller card. This will cause the controller to transmit for approximately 8 seconds.
2. Measure the deviation level using service monitor.
3. Adjust the TX level (2005141 controller card front panel) for 3 kHz deviation. If the bandwidth is 12.5 kHz, then adjust for 1.5 kHz deviation (If using private line, add 0.75 kHz private line deviation to the signal.)

Note, slightly higher S/N levels can be obtained by increasing the RF modulation levels to 4 and 2 kHz depending on the channel spacing and the ability of the radio to produce a clean sinewave at these levels without limiting. Do not exceed these deviation levels. All sites in the system should be set to the same modulation level.

9.4 Control and Status Monitoring

1. Use The Commander Digital System (SFCDWARE) to verify the UVRI has been properly configured for the application. Make any required changes prior to placing the UVRI into service.
2. The control and status monitoring features should be tested from each control point. Test each control function and all status indications using SFCDWARE. Verify each status point provides the proper indication of both pass and fail conditions.

Federal Signal UltraVoice
UVRI Installation and Operation Manual

UVRI Field Test Data								
Customer:		Project Number:		Date:				
Contact Person:		Phone:		Second Phone:				
Radio Shop:		Contact:		Phone:				
Siren Type:		S/N:		Voltage:				
Controller Type:		Antenna: Omni <input type="checkbox"/> Yagi <input type="checkbox"/> Cabinet Mounted <input type="checkbox"/> External Mounted <input type="checkbox"/>		A/C Service: O.H. <input type="checkbox"/> U.G. <input type="checkbox"/>				
CPU Software:		Program file:		SMV:				
Radio Information: Low Band <input type="checkbox"/> VHF <input type="checkbox"/> UHF <input type="checkbox"/> 800 <input type="checkbox"/> Trunk <input type="checkbox"/> 12.5 KHz <input type="checkbox"/> 25 KHz <input type="checkbox"/>								
Radio Frequency: TX RX PL								
Site:		S/N:		Address:		Zone:		
A/C voltage: Vac		Battery voltage:		Charger voltage:				
Battery Type:			Model:			Manufacturer:		
Sensor	State		Sensor / Output		State			
Intrusion Sensor	Pass <input type="checkbox"/>	Fail <input type="checkbox"/>	Audio A/B Sense		Pass <input type="checkbox"/>	Fail <input type="checkbox"/>		
Low Battery	Pass <input type="checkbox"/>	Fail <input type="checkbox"/>	Remote System Operation		Pass <input type="checkbox"/>	Fail <input type="checkbox"/>		
AC Power On	Pass <input type="checkbox"/>	Fail <input type="checkbox"/>	Relay Output		Pass <input type="checkbox"/>	Fail <input type="checkbox"/>		
AC Power Off	Pass <input type="checkbox"/>	Fail <input type="checkbox"/>	Audio Output		Pass <input type="checkbox"/>	Fail <input type="checkbox"/>		
Charger Sense	Pass <input type="checkbox"/>	Fail <input type="checkbox"/>						
Wiring Neatly Dressed in Cabinet: Yes <input type="checkbox"/> No <input type="checkbox"/>				Debris removed from Control Cabinet: Yes <input type="checkbox"/> No <input type="checkbox"/>				
Antenna connectors sealed: Yes <input type="checkbox"/> No <input type="checkbox"/> (Required for outdoor antenna installations)								
Tested by:				Date:				
Notes:								

Figure 9.1 - Field Test Data Sheet

10 MAINTENANCE

PRE-OPERATION CHECK-OUT AND TEST

Federal Signal UltraVoice
UVRI Installation and Operation Manual

WARNING

Service and maintenance should be performed by qualified personnel familiar with the UVRI, associated controls, and power sources being used and in conjunction with the authorities having jurisdiction.

The sound output of speakers is capable of causing permanent hearing damage. Use adequate hearing protection and avoid excessive exposure.

The UVRI series speaker controller is designed to require a minimum amount of maintenance. In addition, experience has shown that all Federal Signal products are highly reliable devices. However, if a failure does occur, Federal will provide technical assistance with problems that cannot be handled satisfactorily and promptly locally. If assistance is desired, contact:

FWS Service Department
Signal Division
Federal Signal Corporation
2645 Federal Signal Drive
University Park, Illinois 60484
(800) 524-3021

Test the UVRI for proper operation at least once a month. A daily test at noon, curfew, or other selected time is preferred. This not only enhances the usefulness of the UVRI and verifies that it remains ready for use when needed; it also instills confidence in the reliability of the system.

In order to minimize the potential for a failure, annual inspection and maintenance is recommended.

GENERAL MAINTENANCE

10.1.1 Signal Operational Check

1. Activate each of the signals from the control point and observe the signal indicators on the control module and the remote PA system. Verify each function sounds the correct signal at the proper volume level for the application.
2. Verify that the system status is reported correctly at the control point. Check each status point to verify both pass and fail conditions are correctly reported. Verify that the relay output closes with each function activated.

10.1.2 Battery Inspection

1. Remove AC power and measure the DC voltage across the DC input connector on the control board. This voltage should be above 12.75 VDC if the battery has been charging for at least 24 hours.
2. The battery will typically need to be replaced every 3-5 years depending on the application environment. The battery life will be diminished if it is left in a discharged state for prolonged periods.
3. Maintain or replace the battery as recommended by its manufacturer; obey local or state laws governing the disposal of lead-acid batteries.
4. Check the battery terminals for corrosion. Clean and grease connectors and terminals, or replace if necessary.

10.1.3 Battery Replacement

Remove all electrical connections from the motherboard before removing the battery. Remove the connectors at JP1, JP2, JP3, JP4, JP6, and JP8 on the motherboard.

The battery is located under the control board mounting plate. The control board mounting plate can be removed by loosening the four screws as shown below.

Federal Signal UltraVoice
UVRI Installation and Operation Manual

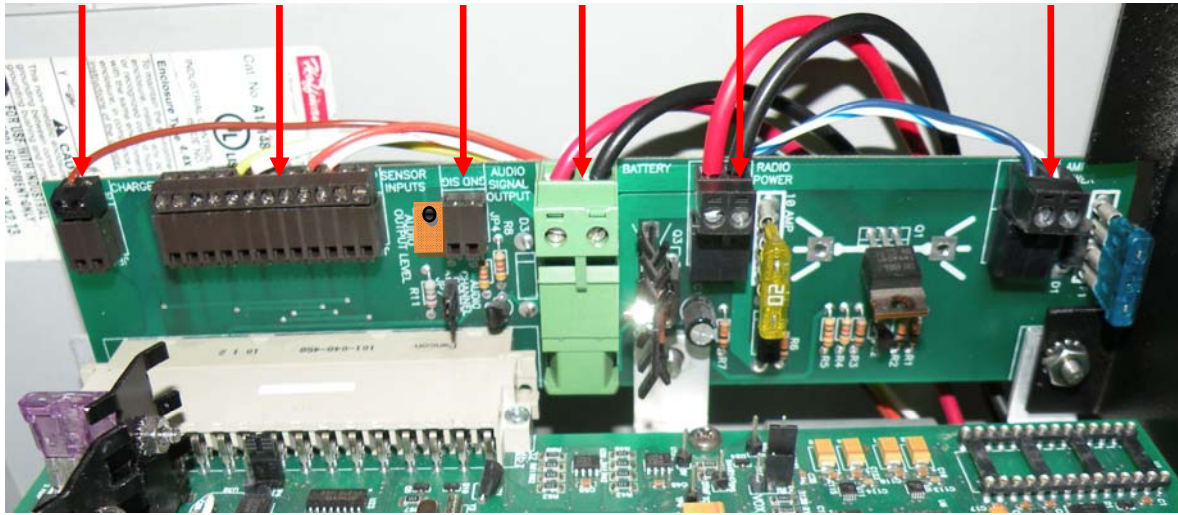

Figure 10.1 – UVRI Motherboard Connections

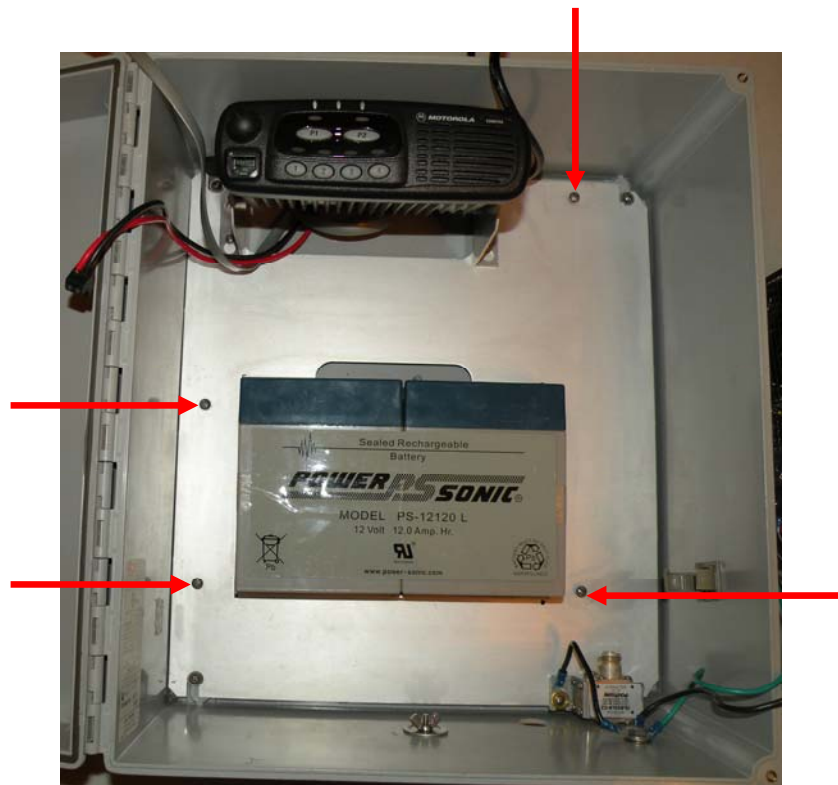

Figure 10.2 - UVRI Battery Location and Cover Plate Mounting Screws

Federal Signal UltraVoice
UVRI Installation and Operation Manual

10.2 Troubleshooting

	PROBLEM	ACTION
1.	NO RADIO DECODE	A. Unit is not programmed to recognize that particular code sequence (or) Signal is not being received properly. B. Verify programming is correct. Check the received audio signal quality at the RX test pin on the front of the control board.
2.	LOW OUTPUT FROM SPEAKERS	Check battery voltage. Also, check signal indicators on amplifiers during a function. If indicators are off, remove amplifier for service.
3.	FUNCTION STOPS BEFORE NORMAL TIME-OUT	Batteries may require further charging. Check battery voltage under load. Check charger output.
4.	LOCAL P.A. FEEDS BACK	Lower P.A. volume using knob above MIC connector.
5.	LOCAL P.A. HAS LITTLE OR NO OUTPUT	Hold MIC close to mouth. Increase PA volume using knob above MIC connector.
6.	BATTERIES NOT HOLDING CHARGE	Check that charger fuses are intact and check charger output. Test batteries.
7.	RELAY OUTPUT ON MOTHERBOARD DOESN'T OPERATE	Check that the relay on the system motherboard is operating (indicated by LED D2). Also check fuse F1 on motherboard (20 amp slo-blow)
8.	RADIO P.A. TAKES TOO LONG TO TIME OUT	Check radio for proper operation of squelch. CD LED should light while carrier is present.
9.	LANDLINE ACTIVATION INPUTS DO NOT FUNCTION	Verify minimum 1- second contact closure is applied to JP14 on the motherboard.

NOTE: For additional help contact the FWS Service Dept. at (800) 524-3021.

11 OPTIONS

11.1 Radio Control

The UVRI can be activated by a radio signal when the optional radio transceiver is incorporated into the Control Unit. Activation by radio control has the advantage that control lines are not required between the control site and the UVRI. Federal Signal offers the controller with a full line of transceivers built in which cover the VHF and UHF bands.

11.2 Digital Voice Recording

Four minutes of digital voice storage is provided as a standard feature with the UVRI. When the Digital Voice Recording option (model DVR) is purchased, the UVRI will be factory programmed with high quality voice or music recordings as specified by the customer.

Up to 16 individual messages may be programmed into the UVRI. Digital Voice Messages may be activated remotely or via the control panel switches. To program activation codes with Digital Voice Messages under them, follow the instructions in the Commander Digital System manual. It is possible to assign codes to the functions DIG VOICE 1 through DIG VOICE 16. As in all sounding functions, the unit must first be sent the ARM command followed by one of the six DIG VOICE commands to activate the stored message. The only adjustment available on the Digital Voice PCB is a potentiometer, which adjusts the audio output level.

11.3 Installation of User Supplied Radio Receivers

CAUTION

Improper installation of radio control equipment may cause the Alert and Notification system to malfunction or operate intermittently. Installation must only be performed by experienced radio technicians who have thoroughly read this manual.

1. TUNING - Tune the radio receiver to the manufacturer's specifications.
2. POWER - Determine the radio power requirements. The ULTRAVOICE control panel provides +12VDC on the RADIO connector on the front panel, as shown below;

Federal Signal UltraVoice UVRI Installation and Operation Manual

RADIO Connector, 8 pin MOD jack;

1. Receive Audio, 150mV – 10V_{p-p}
2. Transmit Audio, 50mV - 3V_{p-p}
3. Carrier Detect - active low
4. PTT
5. +12 VDC
6. GND
7. +12 VDC
8. GND

This voltage source must not be used for radios, which draw more than 1.5 Amps of current in transmit. Use both grounds and both +12 VDC connections for current handling. If a higher current output is required, a 24 VDC – 12 VDC voltage converter must be purchased. This converter is provided with the UVRI series models. Do not use one of the 12 VDC batteries to run the radio equipment.

1. AUDIO – The ULTRAVOICE controller Receive Audio Input should be connected to the de-emphasized Audio Output of the radio. Use shielded audio grade cable and keep wire runs as short as possible. The Receive Audio level can vary from 150 mV – 3V_{p-p} unclipped.
2. The Transmit Audio Output is adjustable from 50 mV - 3V_{p-p}.
3. C.D. - The carrier detect signal from the radio must pull to ground when active. The radio carrier detect signal is useful for controlling live PA. When the C.D. signal is removed from the controller for over 5 seconds, the controller will automatically cancel the P.A. function eliminating the need to broadcast the cancel tones over the speakers.
4. PTT – The PTT output pulls to ground when active to key the radio.
5. RX and TX Audio – Adjust the RX and TX Audio levels as described in Section 6.

11.4 Model UVRI-IP

The UVRI-IP combines the characteristics of a UVRI with Serial to Ethernet conversion capabilities. This allows serial devices to communicate over an Ethernet network and provides audio decoding of digitized audio sent over the network.

The converter is configured with its own fixed IP address and port number. When packets of data are received over the Ethernet port that are addressed to the board's IP and port number, they are converted to serial data and sent out over the serial port. Likewise, any data coming into the serial port is converted to TCP/IP data packets and

Federal Signal UltraVoice
UVRI Installation and Operation Manual

sent out over the Ethernet port to the server's IP address. The unit also contains a digital to analog converter. This allows specially configured incoming data packets to be converted to audio, which is then filtered and sent out over a 600 ohm audio port.

A. Ethernet Board Specifications

Electrical

11.4.1

Input Voltage 10.5 - 95VDC
Current Draw <150 mA

Serial Port

Serial Port Protocol RS232C, N, 8, 1
 baud rate
 configurable

Ethernet Port

Protocol IEEE 802.3, 10
 Base-T connection

600 Ohm Audio Output Port

Protection MOV and Transorb
 surge protection
Impedance 600 ohms
Audio Output Level Adjustable from 0.30 to 3.00 V_{p-p},
(-17 dB to +2.7 dB) into 600 Ohms

*NOTE: To use the 600 ohm input for activation receive audio, a jumper must be across pins 2-3 at JP8. JP8 is located on the main controller card. Refer to section '600 Ohm Adjustment Procedure for Communications'.

Connectors

JP1 600 Ohm Audio Output Port
Balanced line output

JP2 JTAG Emulation port

**JP3 Audio Output Expanded or
Flat Selection Jumper**
Jumper pins 1 & 2 for flat audio output
Jumper pins 2 & 3 for expanded dynamic range audio output

Federal Signal UltraVoice
UVRI Installation and Operation Manual

JP4 RS232 Serial Port

- 1 -
- 2 -
- 3 - Ground, 0.5 amps maximum current capacity
- 4 - Radio transmit data from PC, standard RS232 levels
- 5 - Radio receive data to PC standard RS232 levels
- 6 - Ground, 0.5 amps maximum current capacity

JP5 FLASH Programming and Converter Configuration Port

- 1 -
- 2 - TX Data, standard RS232 levels
- 3 - RX Data, standard RS232 levels
- 4 - Ground
- 5 - Serial Clock input for FLASH programming, standard RS232 levels
- 6 - Processor Reset Not line, used in programming FLASH, 10K pull-up

JP6 10.5-95 VDC Power Input

- 1 - (-)
- 2 - (+)

JP7 Resets board back to factory default settings.

J1 Ethernet Network Port

- 1 & 2 - Transmit data pair, balanced line
- 3 & 6 - Receive data pair, balanced line
- 4, 5, 7, 8 - AC coupled ground

Indicators

- D1 - CPU Heartbeat indicator, green
- D2 - Transmit data indicator, red
- D3 - Receive data indicator, yellow
- D4 - Power indicator, green

Controls

- R1 – 600 ohm audio output level set

Environmental

- Operating Temp. -30 °C - +65 °C
- Humidity 0- 95% non-condensing

Federal Signal UltraVoice UVRI Installation and Operation Manual

Physical

Dimensions ~ 2" height,
4" width,
6.5" length

Weight < 2 lbs

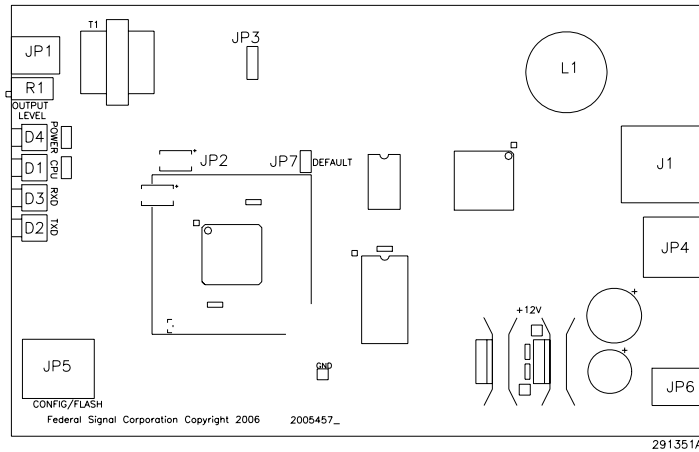

Serial to Ethernet Board

B. Network Information

Protocols Supported

- TCP/IP
- UDP (optional)
- XML (optional)
- XMPP (optional)

IP Ports Used

16,887 (Codespear TCP/IP)
80 (HTTP)
3100 (optional UDP Serial Over IP)
3101 (optional UDP Voice Over IP)

IP Address

User selectable

Federal Signal UltraVoice
UVRI Installation and Operation Manual

TOS/DSCP (Type of Service)

User selectable priority level

Bandwidth Requirements

Voice Over IP: 150K baud per Connection

Siren Activation: 50 bytes per connection

Siren Poll Response: 74 bytes per connection

